

Overview

- The BA#-PP is a small temperature conductive plastic sensor used for single point temperature measurement with twin plenum rated lead wires. It is ideal for mounting applications inside electronic circuit enclosures or existing thermostats.
- The BA#-RPP is a small Stainless Steel (SS) temperature sensor used for single point temperature measurement with PVC plenum rated cable. It is ideal for bracket mounting for Chamber, Duct, Thermowell or L-bracket applications.
- The BA#-RPFEP is a small Stainless Steel (SS) temperature sensor used for single point temperature measurement with FEP plenum cable. It is ideal for bracket mounting in harsh environments for Chamber, Duct, Thermowell or L-bracket applications.
- The BA#-RPFEP2 is a small Stainless Steel (SS) temperature sensor used for single point temperature measurement with submersion FEP plenum cable. It is ideal for bracket mounting in wet or water submersion environments for Chamber, Duct, Immersion or L-bracket applications.

The BA#-(PP, RPP, RPFEP, RPFEP2) units are available in multiple types of 4 to 20mA transmitters that can be ordered with 100Ω (385), 1KΩ (385) RTDs or 10KΩ type 2 thermistor sensors. A 0 to 5VDC or 0 to 10VDC transmitter is also available with the 10KΩ type 2 thermistor sensor. Special high accuracy RTD matched transmitters (M) are available which match the sensor to the transmitter for improved accuracy. Enclosure mounting styles come in plastic or metal for both NEMA 3R and NEMA 4 applications and are all plenum rated.

Identification

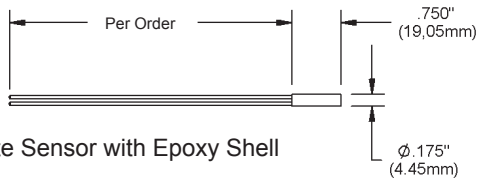

Fig 1: Remote Sensor with Epoxy Shell

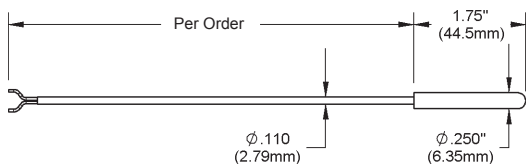

Fig 2: Stainless Steel Remote Probe with Plenum-rated Cable

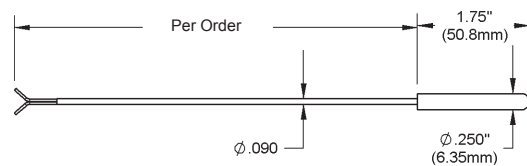

Fig 3: Stainless Steel Remote Probe with FEP Plenum Cable

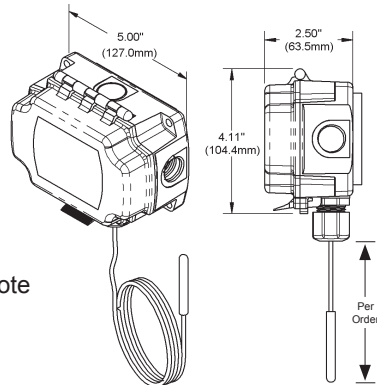

Fig 4: Stainless Steel Remote Probe in a BAPI-Box (BB) Enclosure

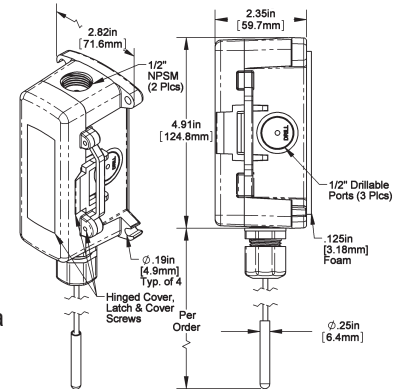

Fig 5: Stainless Steel Remote Probe in a BAPI-Box 2 (BB2) Enclosure

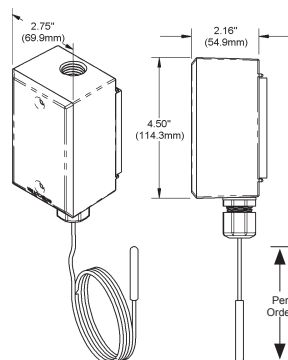

Fig 6: Stainless Steel Remote Probe in a Weatherproof (WP) Enclosure

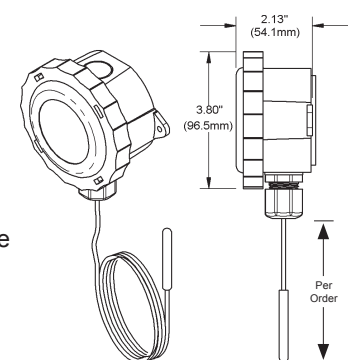
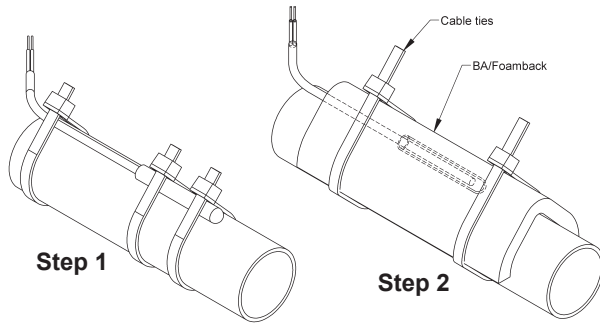

Fig 7: Stainless Steel Remote Probe in a Weather Tight (EU, EUO) Enclosure

Specifications subject to change without notice.

Mounting



Step 1: Secure Sensor To Have Good Contact With Bare Pipe

Step 2: Insulate Over The Sensor (See Notes Below)

Notes: Insulation should be installed a minimum of 4 pipe diameters on each side of the strap-on sensor.

Example: 1/2" pipe x 4 = 2".

Insulation should be 2" on each side of the sensor wrapped all the way around the pipe.

Fig 8: Stainless Steel Remote Probes Strapped to Pipes

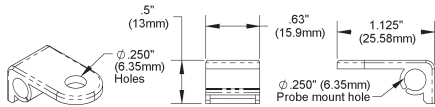

Fig 9-A: Break-Off Tab from a BAPI Flexible Probe Bracket (BA/FP)

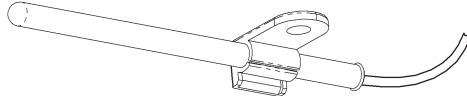

Fig 9-B: Break-Off Tab Used to Mount a Stainless Steel Remote Probe.

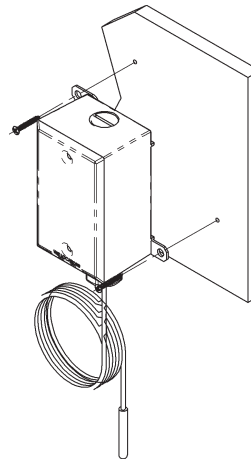

Fig 10: Stainless Steel Remote Probe with Weatherproof (WP) Enclosure

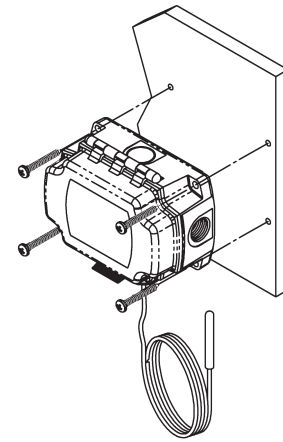

Fig 11: Stainless Steel Remote Probe with BAPI-Box (BB) Enclosure

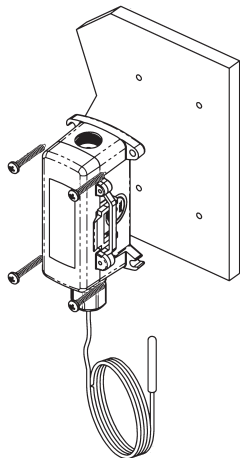

Fig 12: Stainless Steel Remote Probe with BAPI-Box 2 (BB2) Enclosure

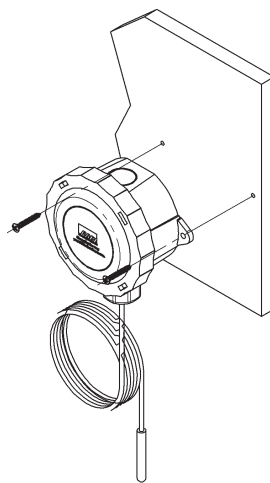

Fig 13: Stainless Steel Remote Probe with Weather Tight (EU, EUO) Enclosure

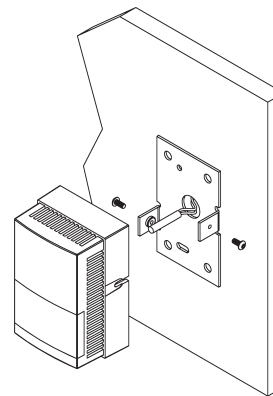

Fig 14: Remote Sensor Shown Installed in a Pneumatic Thermostat

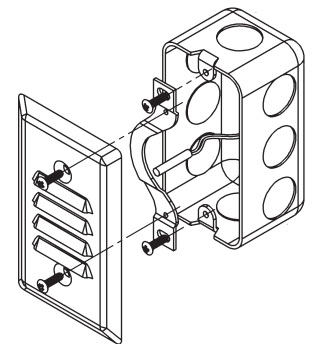

Fig 15: Remote Sensor Shown Installed in an Junction Box with a Wall Plate Cover

Specifications subject to change without notice.

Wiring & Termination

BAPI recommends using twisted pair of at least 22AWG and sealant filled connectors for all wire connections. Larger gauge wire may be required for long runs. All wiring must comply with the National Electric Code (NEC) and local codes. Do NOT run this device's wiring in the same conduit as high or low voltage AC power wiring. BAPI's tests show that inaccurate signal levels are possible when AC power wiring is present in the same conduit as the sensor wires.

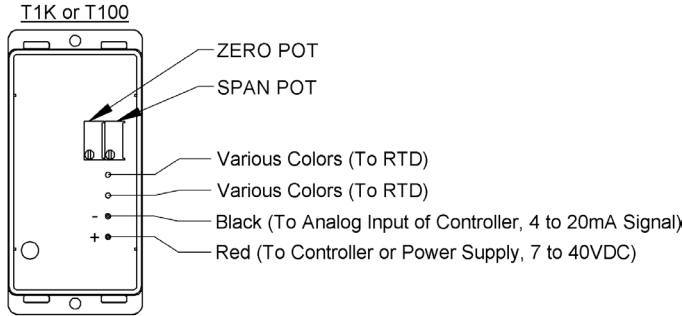

Fig. 16: Typical RTD 4-20 mA Transmitter W/Flying Leads

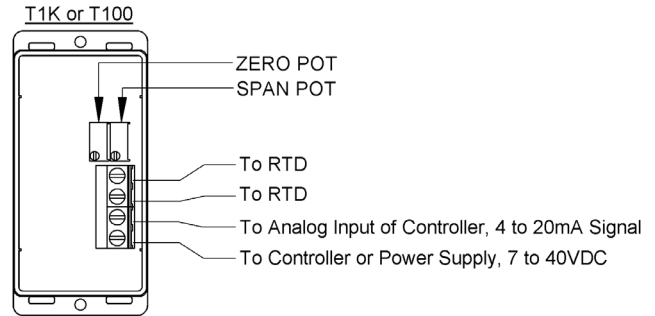

Fig. 17: Typical RTD 4-20mA Transmitter W/Terminals

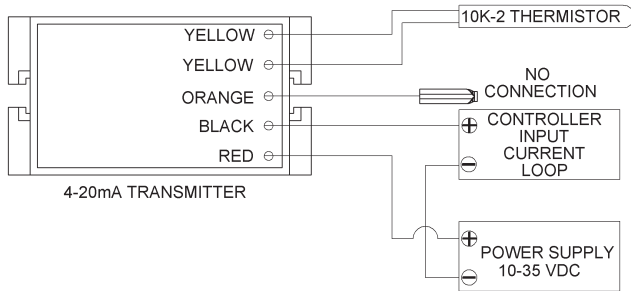

Fig. 18: Typical Thermistor 4 to 20mA Transmitter

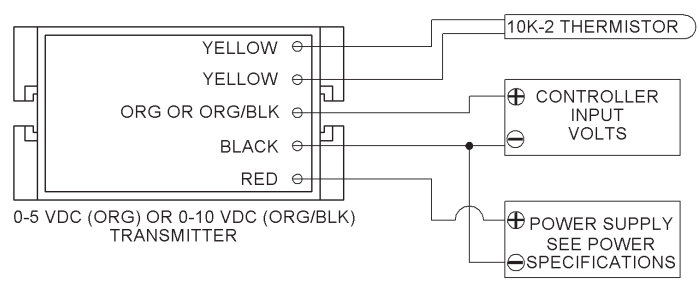

Fig. 19: Typical Thermistor Voltage Transmitter

Diagnostics

Possible Problems:

- Unit will not operate.

Possible Solutions:

- Measure the power supply voltage by placing a voltmeter across the transmitter's (+) and (-) terminal. Make sure that it matches the drawings above and power requirements in the specifications.
- Check if the RTD wires are physically open or shorted together and are terminated to the transmitter.
- Measure the physical temperature at the temperature sensor's location using an accurate temperature standard. Disconnect the temperature sensor wires and measure the temperature sensor's resistance with an ohmmeter. Compare the temperature sensor's resistance to the appropriate temperature sensor table on the BAPI web site.

- The reading is incorrect in the controller.

- Determine if the input is set up correctly in the controllers and BAS software.
- For a 4-20mA current transmitter measure the transmitter current by placing an ammeter in series with the controller input. The current should read according to the "4-20mA Temperature Equation" shown below.
- For a voltage transmitter, measure the signal with a volt meter (Orange or Orange/Black to Black). The signal should read according to the "Voltage Temperature Equation" shown below.

Voltage Temperature Equation

$$T = T_{Low} + \frac{(V \times T_{Span})}{V_{Span}}$$

- T = Temperature at sensor
- T_{Low} = Low temperature of span
- T_{High} = High temperature of span
- T_{Span} = T_{High} - T_{Low}
- V_{Low} = Low transmitter voltage usually=(0, 1 or 2v)
- V_{High} = High transmitter voltage usually=(5 or 10v)
- V_{Span} = V_{High} - V_{Low}
- V = Signal reading in volts

4-20mA Temperature Equation

$$T = T_{Low} + \frac{(A - 4) \times (T_{Span})}{16}$$

- T = Temperature at sensor
- T_{Low} = Low temperature of span
- T_{High} = High temperature of span
- T_{Span} = T_{High} - T_{Low}
- A = Signal reading in mA

Specifications subject to change without notice.



Remote Probe Transmitters and Remote Sensor Transmitters

BA/#-(PP, RPP, RPFEP) Temperature Sensor Installation & Operations

20921_ins_RemoteSen_Active

rev. 04/18/13

Specifications

RTD Transmitter

Power Required: 7 to 40VDC
 Transmitter Output: 4 to 20mA, 850Ω@24VDC
 Output Wiring: 2 wire loop
 Output Limits: <1mA (short), <22.35mA (open)
 Span: Min. 30°F (17°C), Max 1000°F, (555°C)
 Zero: Min. -148°F (-100°C), Max 900°F (482°C)
 Zero & Span Adjust: 10% of span
 Accuracy: ±0.065% of span
 Linearity: ±0.125% of span
 Power Output Shift: ±0.009% of span
 RTD Sensor: 2 wire Platinum (Pt), 385 curve
 Transmitter Ambient: -4 to 158°F (-20 to 70°C)
 0 to 95% RH, Non-condensing

Thermistor Transmitter

Supply Voltage:
 10 to 35 VDC (0 to 5 VDC or 4 to 20 mA Outputs)
 15 to 35 VDC (0 to 10 VDC Output)
 12 to 24 VAC (0 to 5 VDC Outputs)
 15 to 24 VAC (0 to 10 VDC Output)
 Transmitter Output: 4 to 20mA, 700Ω@24VDC
 0 to 5 & 0 to 10VDC, 10KΩ min
 Output Wiring: 2 & 3 wire (See wiring detail on pg. 3)
 Transmitter Limits: -40 to 185°F, (-40 to 85°C)
 Accuracy: ±1.015°C, from (0 to 65°C)
 Linearity: ±0.065°C, from (0 to 65°C)
 Resolution: Span/1024
 Thermistor Sensor: 10K-2 Thermistor, 10KΩ @77°F
 Transmitter Ambient: 32 to 158°F, (0° to 70°C)
 0 to 95% RH, Noncondensing

Thermistor: 10K-2, Thermal Resistor (Bare Sensor)
 Accuracy (Std): ±0.36°F, (±0.2°C)
 Accuracy (High): ±0.18°F, (±0.1°C), [XP] option
 Stability: < 0.036°F/Year, (<0.02°C/Year)
 Heat Dissipation: 2.7 mW/°C
 Probe Range: -40° to 221°F (-40° to 105°C)
 Wire Colors:
 Standard: Yellow/Yellow (no polarity)
 High Acc. [XP]: Yellow/Yellow (no polarity)

RTD: Resistance Temp Device (Bare Sensor)
 Platinum (Pt): 100Ω and 1KΩ @0°C, 385 curve,
 Pt Accuracy (Std): 0.12% @Ref, or ±0.55°F, (±0.3°C)
 Pt Accuracy (High): 0.06% @Ref, or ±0.277°F,
 (±0.15°C), [A]option
 Pt Stability: ±0.25°F, (±0.14°C)
 Pt Self Heating: 0.4 °C/mW @0°C
 Pt Probe Range: -40° to 221°F, (-40 to 105°C)
 Wire Colors: General color code (other colors possible)
 1KΩ, Class B Orange/Orange (no polarity)
 1KΩ, Class A Orange/White (no polarity)
 100Ω, Class B Red/Red (no polarity)
 100Ω, Class A Red/Red-w/black stripe (no polarity)

Sensitivity: Approximate @ 32°F (0°C)

Thermistor: Non-linear - (See www.bapihvac.com, click "Sensor Specs")

RTD (Pt): 3.85Ω/°C for 1KΩ RTD
 0.385Ω/°C for 100Ω RTD

Lead wire 22awg stranded

Wire Insulation

-PP Etched Teflon leads, plenum rated
 -RPP Flame Retardant PVC plenum cable
 -RPFEP FEP jacketed plenum rated cable
 -RPFEP2 FEP jacketed plenum and submersion rated cable

Probe

-PP Heat conductive plastic cup
 -RPP, RPFEP Rigid, 304 Stainless Steel, 0.25" OD

Probe Length

-PP 0.875" (22.2mm)
 -RPP, RPFEP 1.75" (44.5mm)

Mounting

External Probe Bracket required

Probe

Vented polycarbonate shield, 1/2" OD

Probe Length

1.2" with 1/2" NPT threads

Mounting

Extension tabs (ears), 3/16" holes

Wall Gasket

Closed cell foam (impervious to mold)

Enclosure Types

Weather Proof -WP, w/ two 1/2" FNPT entries, (Bell box)
 BAPI-Box -BB, w/ four 1/2" NPSM & one 1/2" drill-outs
 BAPI-Box 2 -BB2, w/ three 1/2" NPSM & three 1/2" drill-outs
 Weather Tight -EU, -EUO, w/ two 1/2" knock-outs

Enclosure ratings

Weather Proof -WP, NEMA 3R, IP14
 BAPI-Box -BB, NEMA 4, IP66
 BAPI-Box 2 -BB2, NEMA 4, IP66
 Weather Tight -EU, NEMA 4, IP66, UV rated

Enclosure materials

Weather Proof -WP, Cast Aluminum, UV rated
 BAPI-Box -BB, Polycarbonate, UL94V-0, UV rated
 BAPI-Box 2 -BB2, Polycarbonate, UL94V-0, UV rated
 Weather Tight -EU, ABS Plastic, UL94V-0, UV rated

Ambient (Enclosure): 0 to 100% RH, Non-condensing

BB, BB2 -40°F to 185°F, (-40° to 85°C)
 EU & EUO -40°F to 185°F, (-40° to 85°C)
 WP -40°F to 212°F, (-40° to 100°C)

Agency

RoHS, CE (CE for all sensors below 10KΩ)
 PT = DIN43760, IEC Pub 751-1983,
 JIS C1604-1989

Related Products

BA/FPB-50 Flexible probe brackets (50 units)
BA/Foamback White foam insulation 2.6" x 4.4" x 0.25 thick

Specifications subject to change without notice.